

SECTION A-A

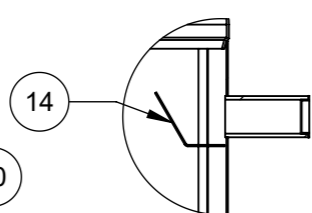

DETAIL C
SCALE 1 : 10

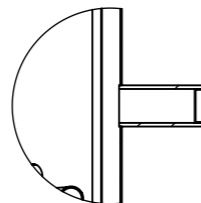

DETAIL D
SCALE 1 : 10

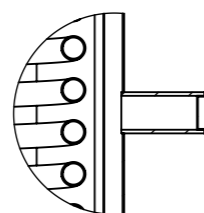

DETAIL E
SCALE 1 : 10

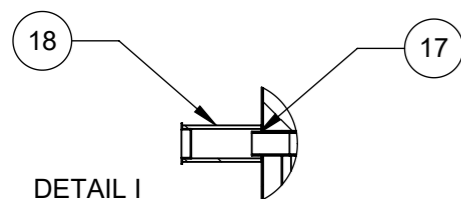

DETAIL I
SCALE 1 : 10

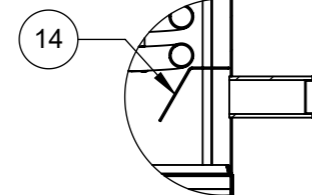

DETAIL F
SCALE 1 : 10

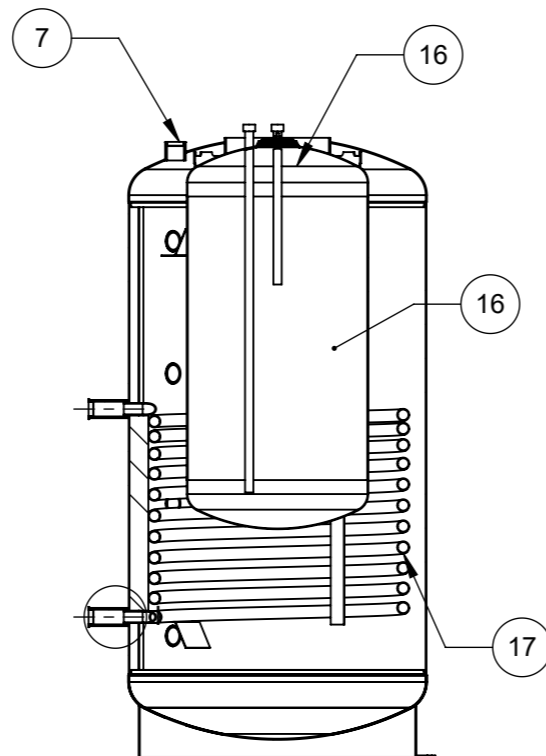

SECTION B-B

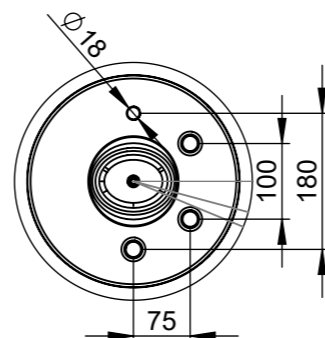
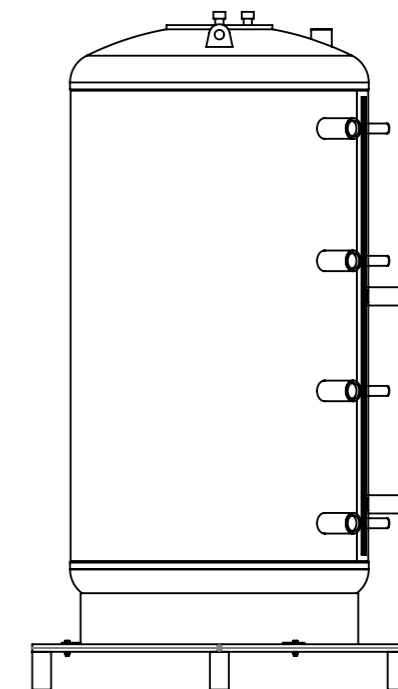
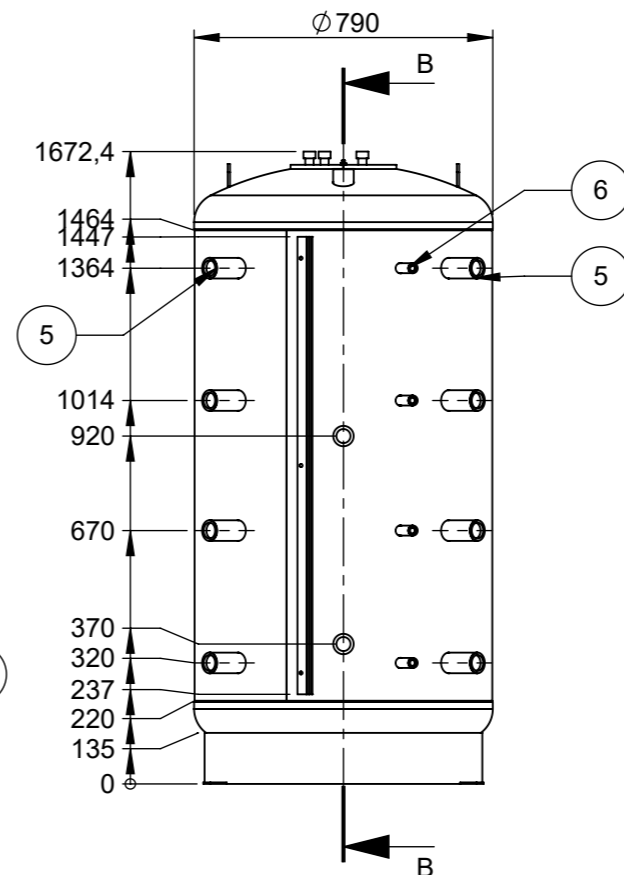

DETAIL H
SCALE 1 : 10

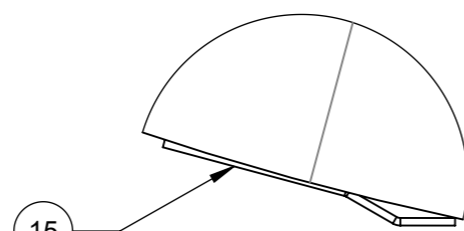
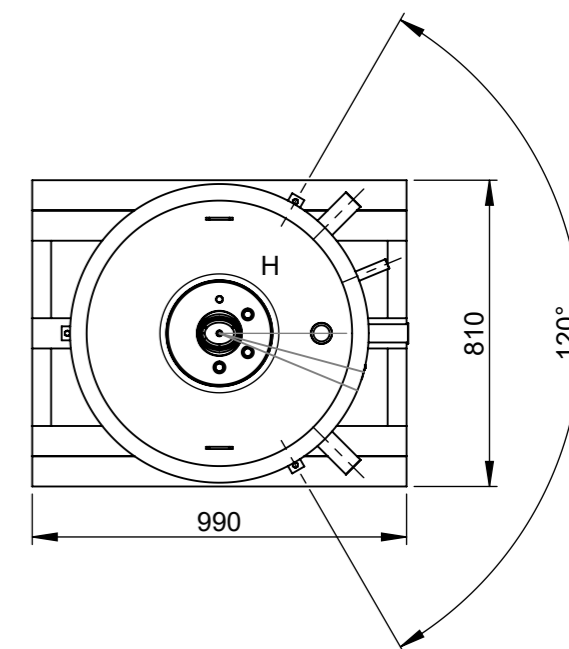
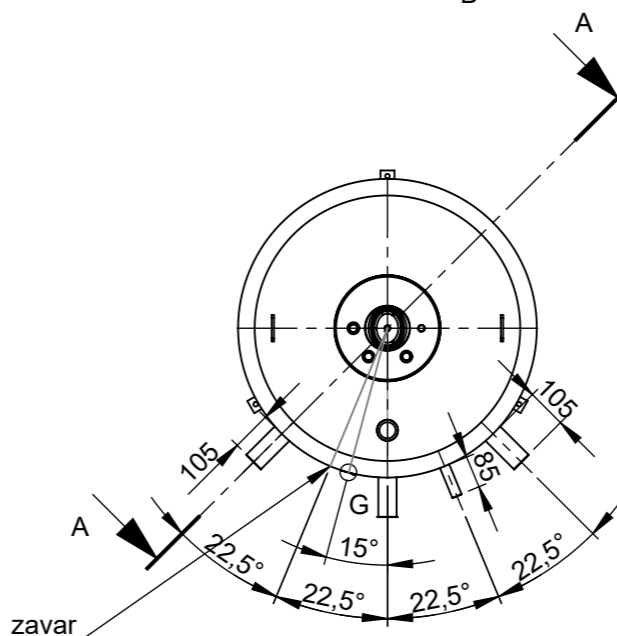

DETAIL G
SCALE 1 : 1

Šifra	Naziv	Kom	
1	76681	Plast spremnika	1
2	35798	Podnica crna fi790x3 - gornja - 800/1000-B/BS	2
3	16379	Podnica crna fi790x3	1
4	27708	Postolje spremnika	1
5	18453	Kolčak crni 6/4" x 110 (54,5x110)	8
6	18997	Kolčak crni 1/2"x90 (fi 26,4x90)	4
7	11151	Kolčak crni 6/4" (54,5x48) DIN 2986/77	1
8	26064	Uška spremnika	2
9	27083	Uška postolja	3
10	27365	Flah za podlogu vara	1
11	17976	Drvena paleta CAS 801/1001	1
12	13129	Vijak M8x35 DIN 933 5,8 Zn	3
13	13134	Matica M8 DIN 934 5.6 Zn	3
14	27173	Usmjerivač vode gornji+donji	4
15	66709	Lajsna CAS-803	1
16	14619	Inox bojler CAS-B/BS 801/1001	1
17	68211	CIJEVNI IZMJENJIVAČ s nosačima fi 690/32x2 (CAS-850)	1
18	17148	Kolčak crni 5/4"x105 (48,3x105)	2
19	28444	PLASTIČNA ZAŠTITA MUFNE 6/4" CRNA	9
20	18800	PLASTIČNA ZAŠTITA MUFNE 1/2" CRNA	4
21	18807	PLASTIČNA ZAŠTITA MUFNE 5/4" CRNA	2

Naziv dijela	Sklop	187.8kg	Material <not specified>	0	
		Masa	Materijal	kom	
	Datum	Ime i prezime		Potpis	
	Crtao	13.12.2022.	Petar Perčić		
	Konstruirao				
Mjerilo	Akumulacijski spremnik CAS-BS 803			Grupa	Rev.br.
1:20					00
				Broj pozicije	
				76633	

Centrometal
TEHNIKA GRIJANJA