

SECTION A-A

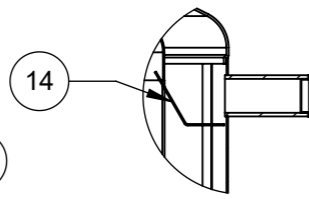

DETAIL C
SCALE 1 : 10

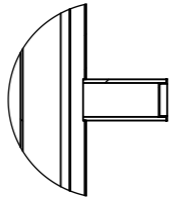

DETAIL D
SCALE 1 : 10

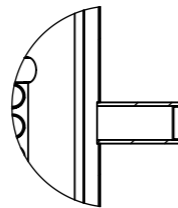

DETAIL E
SCALE 1 : 10

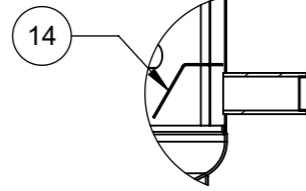

DETAIL F
SCALE 1 : 10

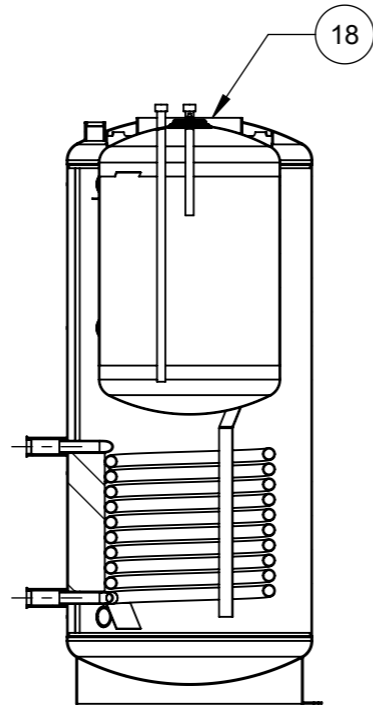

SECTION B-B

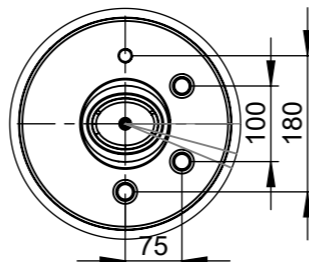

DETAIL H
SCALE 1 : 10

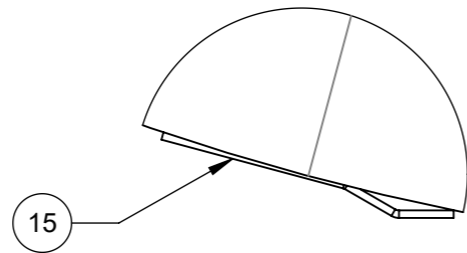

DETAIL G
SCALE 1 : 1

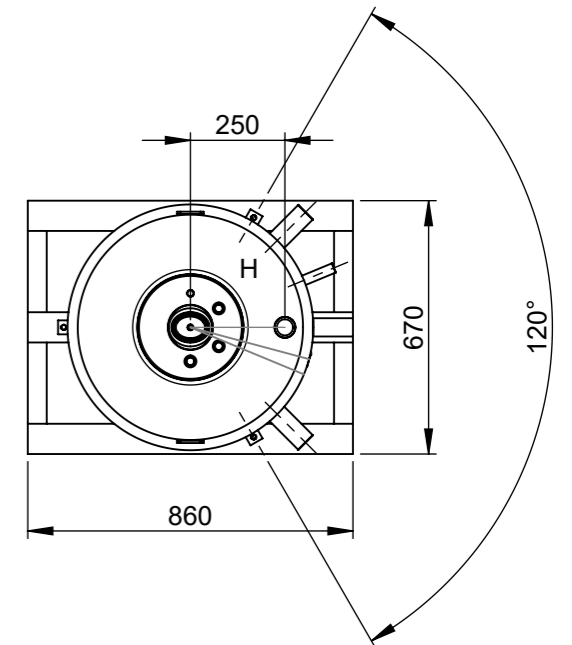
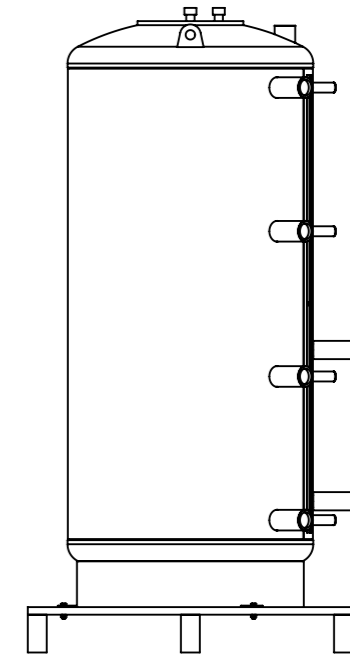
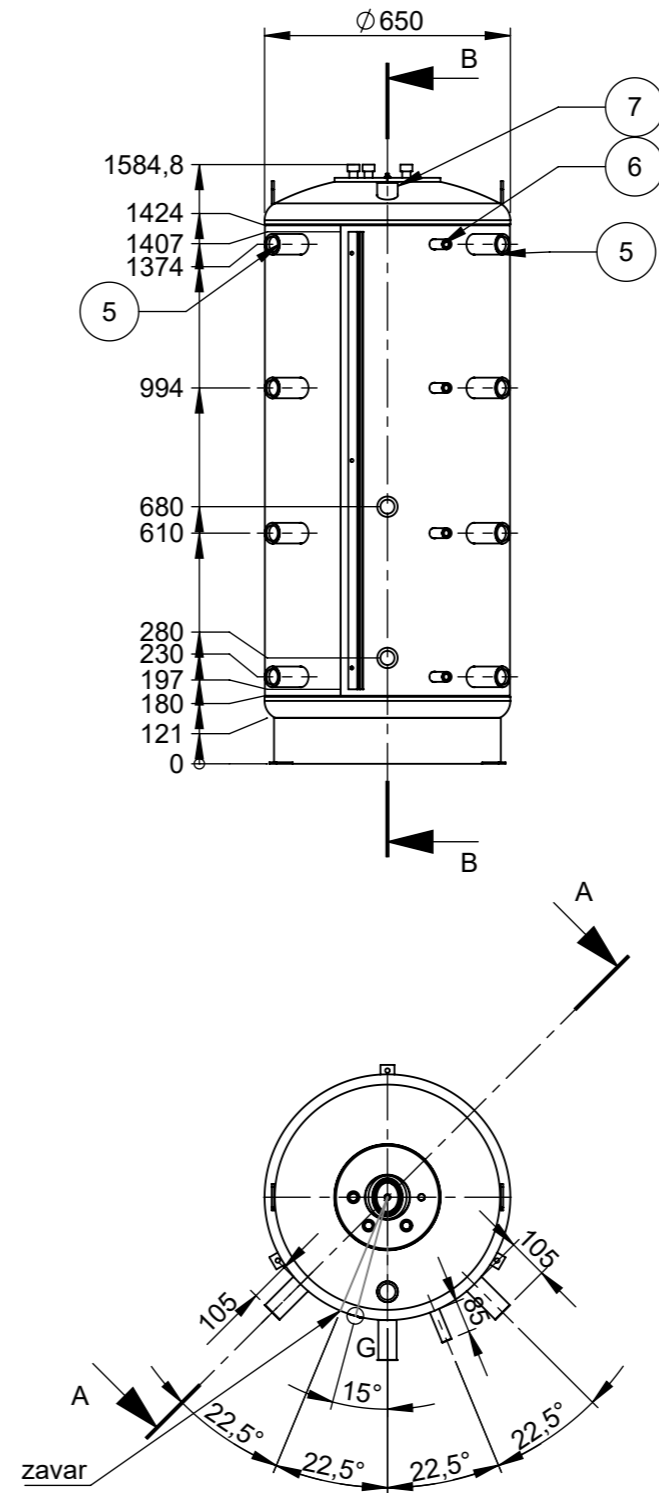

Šifra	Naziv	Kom	
1	76685	Plast spremnika	1
2	35789	Podnica crna fi650x3 - gornja - CAS B/BS	1
3	27688	Podnica crna fi650x3 - donja	1
4	27364	Postolje spremnika	1
5	18453	Kolčak crni 6/4" x 110 (54,5x110)	8
6	18997	Kolčak crni 1/2"x90 (fi 26,4x90)	4
7	11151	Kolčak crni 6/4" (54,5x48) DIN 2986/77	1
8	26064	Uška spremnika	2
9	27083	Uška postolja	3
10	27365	Flah za podlogu vara	1
11	19562	DRVENA AMBALAŽA CAS-501 (860x670) samo donja	1
12	13129	Vijak M8x35 DIN 933 5,8 Zn	3
13	13134	Matica M8 DIN 934 5,6 Zn	3
14	27173	Usmjerivač vode gornji+donji	4
15	66709	Lajsna CAS-803	1
16	28444	PLASTIČNA ZAŠTITA MUFNE 6/4" CRNA	9
17	18800	PLASTIČNA ZAŠTITA MUFNE 1/2" CRNA	4
18	14604	Inox boiler CAS-B/BS 501	1
19	68210	CIJEVNI IZMJENJIVAČ s nosačima fi 450/32x2 (CAS-500)	1
20	17148	Kolčak crni 5/4"x105 (48,3x105)	2
21	18807	PLASTIČNA ZAŠTITA MUFNE 5/4" CRNA	2

Naziv dijela	Sklop	127.0kg	Material <not specified>	0
		Masa	Materijal	kom
	Datum	Ime i prezime		Potpis
	Crtao	14.12.2022.	Petar Perčić	
	Konstruirao			
Mjerilo	Akumulacijski spremnik CAS-BS 503			Grupa
1:20				Rev.br. 00
				Broj pozicije 76637

